



NEW

MATIC700

Smontagomme professionale
automatico senza leva

Touchless automatic
tyre changer



**NEW**

MATIC700

Smontagomme professionale automatico senza leva

Touchless automatic tyre changer



- Smontagomme superautomatico per ruote convenzionali, ribassate e run flat di autovetture e veicoli commerciali leggeri da 10" a 34"
- Mandrino di bloccaggio ruota con centraggio a coni e doppia velocità di rotazione
- Stallonatore a rullo ribaltabile
- Braccio stallonatore a rullo sganciabile per aumentare lo spazio di lavoro
- Equipaggiamento standard con dispositivo Press Arm per agevolare operazioni di montaggio pneumatici Run Flat e Uhp
- Innovativo dispositivo di montaggio/ smontaggio QX, che permette di eliminare la leva alzatallone, pur mantenendo le caratteristiche di un sistema tradizionale
- Sollevatore ruota, per sollevare il pneumatico ed agevolare il posizionamento della ruota sul mandrino di bloccaggio (portata max. 80kg)



- Superautomatic tyre changer for conventional wheels, low profile and Run Flat tyres, cars and light commercial vehicles, from 10" to 34".
- Spindle locking, wheel centering cone and dual speed.
- Reversible bead breaker tool.
- Releasable bead breaker tool for increased workspace.
- Standard equipment with Press Arm device for easy assembly operations of Run Flat and UHP tyres.
- Innovative mounting / dismantling QX device, which eliminates the lever, while maintaining the characteristics of a traditional system.
- Wheel lift, for an easy and quick positioning of the wheel on the spindle lock (max. 80kg).



- Démonte-pneus super automatique pour roues standard, baissées et run flat de voitures et véhicules commerciaux légers de 10" à 34"
- Mandrin de blocage de la roue avec centrage par cônes et double vitesse de rotation.
- Détalonneur avec rouleau basculant
- Bras détalonneur avec rouleau décrochable pour augmenter l'espace de travail
- Equipement standard avec dispositif Press Arm pour aiser les opérations de montage des pneus Run Flat et Uhp
- Dispositif innovatif de montage/ démontage QX qui permet d'éliminer le levier soulève-talons tout en maintenant les caractéristiques d'un système traditionnel.
- Élévateur roue pour soulever le pneu et aiser le positionnement de la roue sur le mandrin de blocage (portée maxi 80kg).



- Superautomatisches Reifenmontiergerät für traditionelle Räder, Niederquerschnittsreifen und Run-Flat von PKWs und Kleintransportern (von 10" bis 34").
- Spanndorn mit doppelter Drehgeschwindigkeit und Radzentrierung mit Konen.
- Kippbarer Wulstabdrücker.
- Aushängbarer Wulstabdrücker-Arm spart Arbeitsplatz.
- Standard-Ausrüstung mit Press-Arm zur leichten Montage von Run-Flat- und Uhp-Reifen.
- Innovatives QX-System zur Reifenmontage und -demontage ohne Montiereisen unter gleichzeitiger Beibehaltung des traditionellen Systems.
- Radlift zum Heben und leichten Positionieren des Rades auf dem Spanndorn (Max. Traglast 80kg).



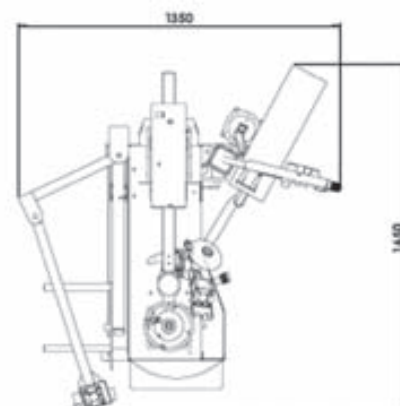
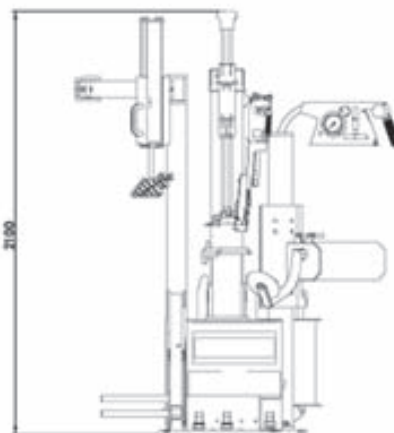

Dati tecnici

Standard features

Données techniques

Technische Daten

Matic700

Bloccaggio cerchio interno	Rim Clamping	Blocage jante intérieure	Felgenblockierung von Innen	10" - 34"
Diametro max. ruota	Max wheel diameter	Diamètre maxi roue	Max. Raddurchmesser	1200 mm (47")
Larghezza max. ruota	Max wheel width	Largeur maxi roue	Max. Radbreite	406 mm (16")
Pressione d'esercizio	Operating pressure	Pression de service	Betriebsdruck	8 - 10 bar
Alimentazione elettrica	Power supply	Alimentation électrique	Stromversorgung	400V 50Hz 3ph.
Velocità di rotazione	Rotating speed	Vitesse de rotation	Drehgeschwindigkeit	7 - 14 rpm (2 speeds)
Potenza motore	Motor Power	Puissance du moteur	Motorleistung	0,8-1,1 Kw
Coppia max. mandrino	Max spindle torque	Couple max. mandrin	Max. Drehmoment Spanndorn	1200Nm
Limitatore pressione gonfiaggio max.	Inflating pressure limiting device	Limiteur de pression de gonflage maxi	Max. Reifenfülldruckbegrenzung	3,5 bar (50psi)
Peso netto	Net weight	Poids net	Nettogewicht	425 kg

DOTAZIONE STANDARD - STANDARD ACCESSORIES - EQUIPEMENT STANDARD - STANDARD ZUBEHÖR



Cono di bloccaggio cerchio con ghiera rapida e perno

Dispositivo di gonfiaggio standard con manometro

Pasta lubrificante, con pennello dispensatore

Levetta in plastica per talloni

Morsetto premitallone

Protezione per cono di bloccaggio

Protezione per perno di trascinamento del sistema di centraggio

Protezioni in gomma a mezza luna per cerchi in lega e Pneumatici Run Flat



Clamping ring cone with fast ring nut and pin

Inflation device with gauge

Lubricating paste with brush dispenser

Plastic lever

Bead clamp

Clamping cone protection

Protection for pin drive system centering

Protective rubber half-moon for alloy rims and tires



Cône de blocage jante avec collier rapide et goujon

Dispositif de gonflage standard avec manomètre

Pâte lubrifiante avec brosse pour l'application

Levier en plastique soulève-talons

Griffe presse talons

Protection pour cône de blocage

Protection pour goujon d'entraînement du système de centrage

Protections en caoutchouc en forme de demi-lune pour jantes en alliage et pneus Run Flat



Felgenblockierkonus mit Schnellspannrad und Stift

Standard-Befülleinrichtung mit Manometer

Schmierpaste mit Pinsel und Behälter

Kleiner Kunststoffhebel für Reifenwulst

Wulstniederhalter

Schutz für Blockierkonus





Schutz für Zentrier-Mitnehmstift

Halbmondförmiger Gummischutz für Leichtmetallfelgen und Run-Flat-Reifen



QX DEVICE



-  QX è un dispositivo innovativo che permette all'operatore di eliminare la leva, utilizzando lo smontagomme in maniera tradizionale nello smontaggio/montaggio dei pneumatici convenzionali, ribassati e Run Flat.
-  QX is the original tire mounting/demounting system (patented technology) with no use of tyre lever. Suitable for conventional, low profiled and Run Flat tyres, it gives the chance to operate without traditional tyre bar, though it keeps the same tyre changing procedure as the conventional one used by tyre specialist so far.
-  QX est un dispositif innovateur qui permet à l'opérateur d'éliminer le levier en utilisant le démonte-pneus de façon traditionnelle dans le montage/démontage des pneus standard, à profil surbaissé et Run-Flat
-  QX ist das Original-System zur Reifenmontage und -demontage (Patent-Technologie), bei dem kein Montiereisen mehr nötig ist. Geeignet für konventionelle, Niederquerschnitt- und Run-Flat-Reifen. Ohne den Einsatz des traditionellen Hebels kann der Reifenspezialist wie bisher gewohnt verfahren.

WHEEL LIFT



CONTROL UNIT

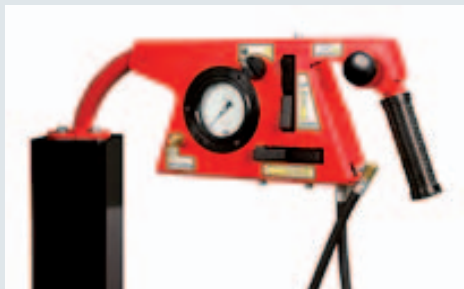

Alcuni nostri clienti / Some of our customers:

FERRARI • MASERATI • LAMBORGHINI •
MERCEDES-BENZ • BMW • VOLKSWAGEN • FIAT •
LANCIA • ALFA ROMEO • FORD NISSAN • RENAULT
• HARLEY DAVIDSON • HONDA • YAMAHA • SUZUKI
• KAWASAKI • KTM • DUCATI • TRIUMPH • APRILIA -
PIAGGIO • MOTO GUZZI • PIRELLI • BRIDGESTONE
• MICHELIN • CONTINENTAL • DUNLOP •
GOODYEAR • BREMBO • METZELER



CEMB

BALANCING MACHINES



CEMB S.p.A.

Via Risorgimento, 9
23826 Mandello del Lario (LC) Italy
www.cemb.com



Garage equipment division CEMB - ITALY

Plant and Training Center
phone +39 0341 706369
fax +39 0341 700725
garage@cemb.com

CEMB USA

BL Systems Inc.

2873 Ramsey Road
Gainesville, GA 30501 - USA
Phone +001 678 717 1050
Fax +001 678 717 1056
sales@cemb-usa.com

